

Technical data | TEWS - series

- Available from 200 to 15,000 Nm
- Freely rotatable gearbox
- Fast and precise
- 2-speed gear box right/left
- 200 torque settings
- User-friendly design
- Are fitted with a torque cutoff system, giving an accuracy of +/- 3.5% under unchanging conditions
- Are fast, precise and safe and make little noise
- Are available in 230 volt and 110 volt versions
- Have clockwise and counterclockwise rotation, a 2-speed gearbox, and can be adjusted to 200 different torque ranges
- Free positioning of the control unit; the drive motor can rotate freely around 360° - this allows the device to be comfortably positioned on the screw connection
- Have a newly designed drive motor which is characterized by extreme power reserves and is very robust and easy to maintain
- Can be optionally equipped with load activation, enabling an independent release of the twist occurring between the slip nut and support. During this process, the drive motor turns in the reverse direction for a short time. This option is essential for short installation times and offers an ultimate degree of safety.

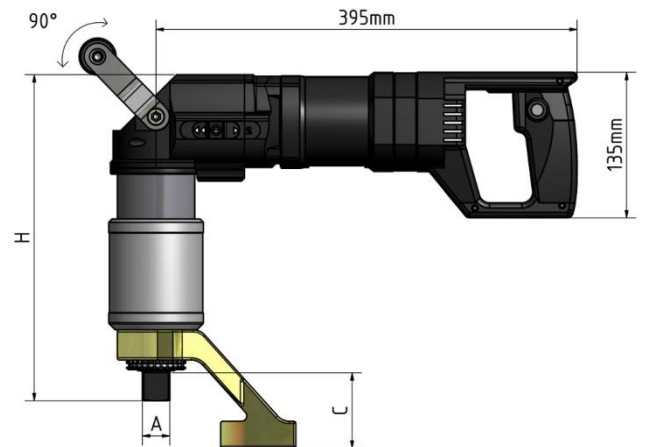

TYP / TYPE		TEWS - 84	TEWS - 104	TEWS - 244	TEWS - 354	TEWS - 504	TEWS - 604	TEWS - 904	
Standard Getriebeeinheit		TEWSL - 84	TEWSL - 104	TEWSL - 244	TEWSL - 354	TEWSL - 504	TEWSL - 604	TEWSL - 904	
Standard gearbox		***	***	***	***	***	***	***	
Art.-No. TEWS -		51 084 200	51 104 210	51 244 220	51 354 230	51 504 240	51 604 250	51 904 260	
Art.-No. TEWSL -		51 084 400	51 104 410	51 244 420	51 354 430	51 504 440	51 604 450	51 904 460	
Leistung / Torque (Nm)		Nm	150 - 850	280 - 1.200	360 - 2.500	360 - 3.500	700 - 5.000	816 - 6.000	1.024 - 10.000
Antriebsvierkant / Square drive	A	Zoll inch	¾" / 1"	1"	1"	1 ½"	1 ½"	1 ½"	1 ½"
Höhe (mm) / Height	C	mm	55-75	75	75	95	95	110	110
Getriebe Ø / Gear diam. (mm)	D	mm	88	88	88	88	130	130	
Höhe / Height (mm)	H	mm	265 / 275	275	305	315	365	350	390
Reaktionsarm / torque support (kg)		kg	1,6	1,6	1,6	3,5	3,5	5,7	5,7
Gewicht / Weight (kg) *		kg	9,5 / 9,7	9,9	11,5	12,3	14,4	18	20,8
Leerlaufdrehzahl / Idle speed (rpm) **		U/m r/m	16	14	10	9	3	6,5	2,5

* ohne Reaktionsarm / without torque support

** 2. Gang / 2. speed gear

*** Bei max. Belastung nicht für Dauereinsatz geeignet / at max. load not appropriate for continuous operation

Technische Änderungen vorbehalten / Subject to technical changes